

Advantages / Characteristics

1) EXCELLENT HEAT INSULATION AND EXTREMELY LOW MOISTURE VAPOR PERMEABILITY

The closed cell structure of XCELLON, a cross-linked Polyethylene foam, promotes extremely low thermal conductivity for excellent heat insulation. and XCELLON exhibits extremely low moisture vapor permeability to maintain heat insulating properties over a long period of time.

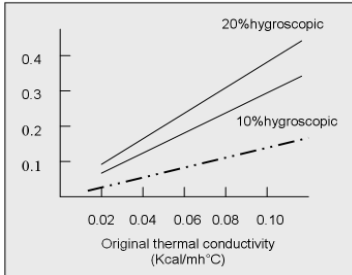

INCREASE IN THERMAL CONDUCTIVITY AFTER GETTING HYGROSCOPIC.

ITEM	DENSITY	Thermal Conductivity	WATER RESISTANT	WEATHER PROOFNESS
PE FOAM (XCELLON)	0.025G/Cm3	0.029Kcal/mh°C	⊙	⊙
PS FOAM	0.015g/Cm3	0.031Kcal/mh°C	Δ	Δ
PU FOAM	0.025g/Cm3	0.032Kcal/mh°C	x	x
GLASS WOOL	0.01g/Cm3	0.034Kcal/mh°C	x	○
HEMP FELT	0.017g/Cm3	0.037Kcal/mh°C	x	x
PLASTER BOARD	0.9g/Cm3	0.098Kcal/mh°C	x	○
WOODTIP BOARD	0.7g/Cm3	0.013Kcal/mh°C	x	x

COMPARISON OF HEAT INSULATING MATERIALS (AT 0°C)

2) DEW PREVENTION

As a superior thermal insulating and semirigid foam, XCELLON exhibits close adhesion to piping and thus is very effective in dew free applications.

Unlike other polyurethane foam and glass wool, XCELLON prevents dew formation in its cells.

3) FLEXIBLE, CUSHIONING, AND SOUND/VIBRAT DAMPENING PROPERTIES

As a semi-rigid foam, XCELLON has excellent cushioning properties for vibration dampening.

4) CONSISTENT DURABILITY

Since polyethylene is being used as the base material of XCELLON, XCELLON is durable and highly resistant to heat. Adverse weather conditions and most of chemicals.

ITEM	PE FOAM (XCELLON)	PU FOAM	PS FOAM
COLOUR	NO CHANGE	CHANGE TO DARKBROWN	NO CHANGE
SHAPE	"	WEATHERED, SCATTERED/DISPERSSED	WEATHERED, SCATTERED/DISPERSSED
SURFACE	"	HARDENED, ERODED	ERODED, RUGGED
SHRINKAGE	ALMOST NO SHRINKAGE	SERIOUS SHRINKAGE	NOT CLEAR DUE TO SCATTERING DISPERSION
TENSILE STRENGTH	90%	49%	50%
ELONGATION	90%	64%	0%

RESULTS OF WEATHER TEST ON FOAMS FOR ONE YEAR PERIOD

TEST PURPOSE & METHOD	THERMAL CONDUCTIVITY	PASSED
CHEMICAL RESISTANT (20°C, IMMERSER FOR 24 HRS) KSM 3007	1. 30% SULFURIC ASID	"
	2. 30% SODIUM HYDRDO OXIDE	"
	3. 30% SODIUM CARBONATE	"
	4. 30% HYDRO PEROXIDE	"
	5. 30% ETHANOL	"
	6. 30% BENZENE	"

RESULTS OF CHEMICAL RESISTANCE OF PE FOAM (XCELLON)

NON - FLAMMABILITY

Non - flammable grade is also available with XCELLON: it is self-fire extinguishable and emits no poisonous gas

DUCT Insulation

CHARACTERISTICS

The closed cell, cross-linked, and semirigid XCELLON sheet is low in thermal conductivity and thus suitable for heat insulation. It's non- hygroscopic feature presents consistent heat insulating properties and is excellent in preventing dew formation caused by differences in temperatures. Its capability of easy fabrication and close adhesion to duct makes XCELLON an excellent choice for any shape of duct covering

APPLICATIONS

- DUCT COVER IN CONSTRUCTION (BUILDING/FACORY)
- DUCT COVER IN BUS/RAILROAD CARRIAGE
- OTHERS



SQUARE/RECTANGULAR DUCT COVER FOR INSULATION



ROUND DUCT COVER FOR INSULATION

XCELLON TAPE OR ALUMINUM FOIL LAMINATED TAPE

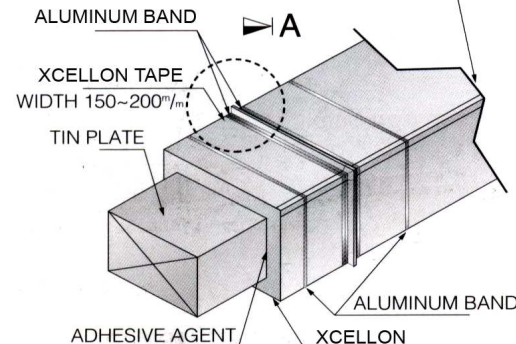

PIPE Insulation

CHARACTERISTICS

XCELLON can be used at temperatures up to 120°C. It is suitable for all pipings except steam lines and can be easily converted and fabricated into any shape. It is more economical than multiscene plastic foam.

APPLICATIONS

Heat insulating pipe cover for central heating, under-Floor heating, central air conditioning, split air conditioning, sanitary piping, cooling piping, freezing piping, etc.



ALUMINUM FOIL LAMINATED



LARGE PIPE INSULATION



FIRE RETARDANT GRADE



SIDE COVER IN AHU

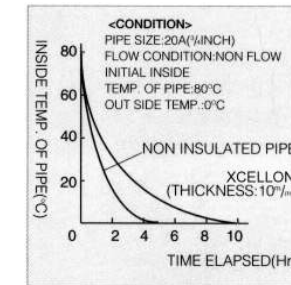

HEAT INSULATING EFFECT (INSIDE TEMP DROP OF PIPE)

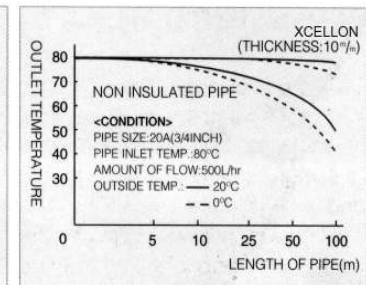

HEAT INSULATING EFFECT (LENGTH OF PIPE AND PIPE OUTLET TEMP.)

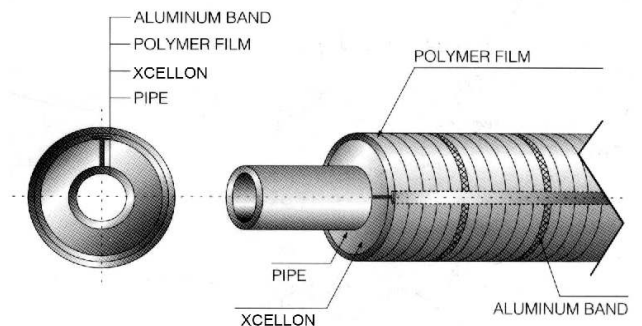

Product Description

TECHNICAL DATA

Xcellon foam is produced by combining chemical cross-linking agent with polyethylene resin. When heat is applied in the foaming process, the cross linking agent reacts and chemically ties the foam's cellular chains together in a strong, cross-linked carbon bond creating a solid unified mass. The resulting foam produced is closed cell, durable, flat and smooth surface.

Application

- Piping Insulation
- Ducting Insulation
- Steel Sheet/Roofing Insulation
- Automobile Interior and Panels
- Packaging
- Tapes
- Cushioning and Sound/Vibration Dampening
- Sports and Leisure

Properties	Value
Density	2.0 PCF 0.034 g/cm ³
Thermal Conductivity @ 10 ⁰ C	0.031 W/mk
Thermal Conductivity @ 40 ⁰ C	0.035 W/mk
Temperature Limits ⁰ C	-70 ⁰ C up +120 ⁰ C
Water Absorption	0.000073 g/cm ³
Water Vapour Permeability	Below 0.1%
Ozone Resistance	Excellent
Thermal Stability 22 hrs 70 ⁰ C	L 20 %
Shrinkage (%)	W 0.5%
Average Spread of Flame	Class 1
Average Time of Burning	Less than 5 seconds
Average extend of burning	minor
Flexibility	Excellent
Weather and Ultraviolet Rays	Excellent
Chemical Resistance	Excellent
Odour	None
Mildew Resistance	No fungal Growth

PHYSICAL DATA

Properties	40 Times Expansion
Density	0.026 g/cm ³
Tolerance	0.004
Tensile Strength	
LENGTH	2.5 kgf/cm ²
WIDTH	1.8 kgf/cm ²
Elongation	
LENGTH	120%
WIDTH	110%
Tear Strength	
LENGTH	1.3 kgf/cm
WIDTH	1.2 kgf/cm
Hardness CV-Type (degree)	13

XCELLON



Fermon Corporation
 Molave Estate, Paliparan
 Dasmariñas, Cavite Philippines 1140
 Phone: +63 (46) 852-2120o 07
 Fax: 6700-1187 / 6700-1942 (toll free)

Makati Sales Office
 Phone: +63 (2) 889-6976
 +63 (2) 813-8534

Betafoam Corporation
 Dasmariñas, Technopark, Governor's Drive
 Paliparan Dasmariñas, Cavite Philippines 1140
 Phone: +63 (46) 852-2706 to 07
 Telefax: +63 (2) 520-8036 or 520-8715

CROSS-LINKED POLYOLEFIN FOAM
AIR DUCT and PIPE
INSULATION